

Rimoldi®

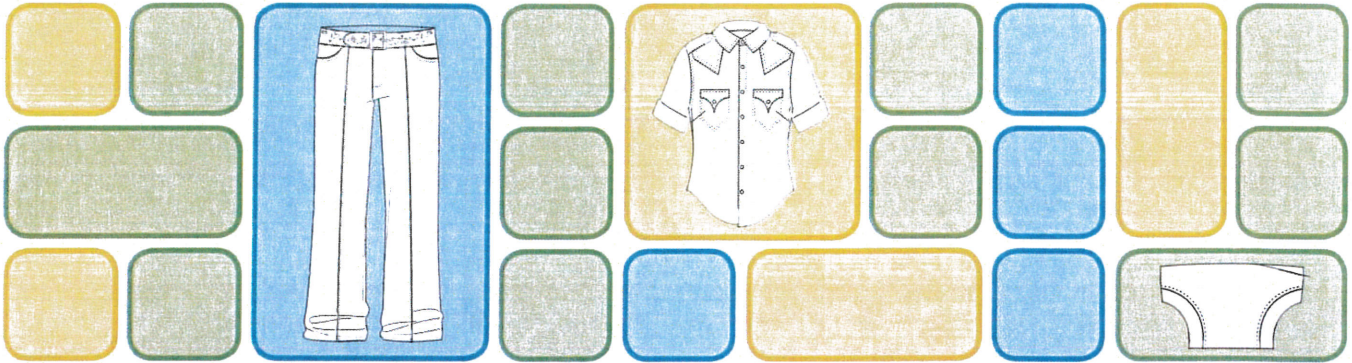

QUALITY RECOGNIZED WORLDWIDE AT VERY COMPETITIVE PRICE



LIBRA

6.200 RPM

181-183

4.200 RPM

F84

Feed-off-the-arm
heads for assembling
seams on a wide
range of fabrics

casual and sportswear
underwear
seamless
tights
medical items

 made in Italy



Feed-of-the arm heads for closing knit garments and hosiery at the sides.
The high working speed ensures maximum productivity with absolute top quality, complete sewing reliability and best ergonomic working position

The trimming knife unit consists of a mobile knife located above another knife fixed firmly to the presser foot: it trims both of the pieces of fabric to be assembled thus providing a flat seam and aiding fabric feed

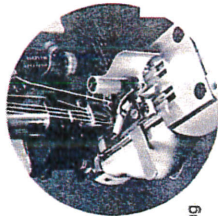

The special shape of the small-diameter cylindrical cross-section base allows even small sized tubular garments to be closed

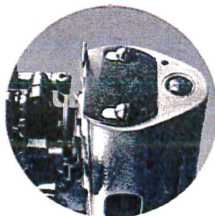

A micrometric mechanical presser foot lifting system which allows feed using elastic blocks; this allows light and delicate fabrics to be sewn and pre-existing seams to be crossed without damage

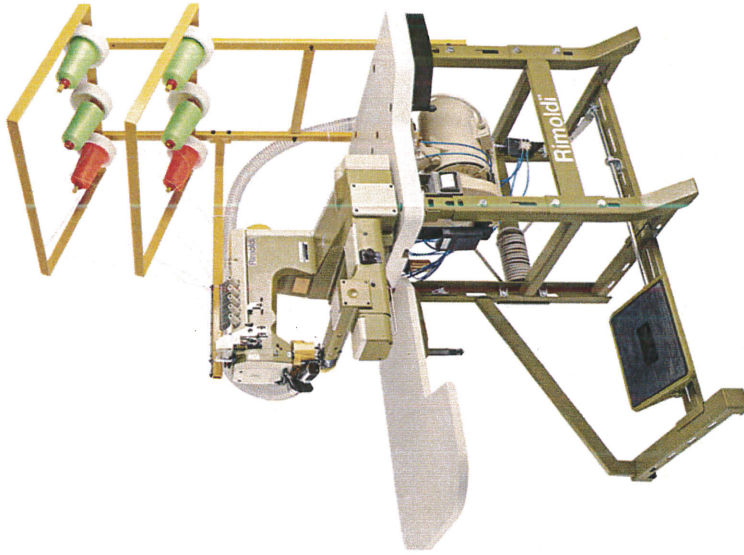

For assembly seams with butted or overlapping edges

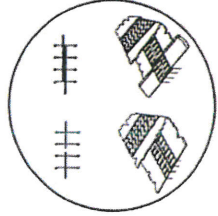

Stitch regulating cam with push-button control and graduated scale on the handwheel in order to read off the stitch length required

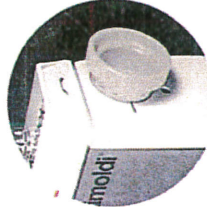

Independent adjustment of needle thread feed which allows the rate of thread fed to each needle to be decided separately according to the elasticity of each thread

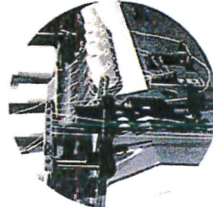

Differential feed which may be easily adjusted using an external lever even when the machine is running

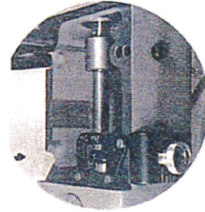

The looper thread tensioning cam located on the left extension of the main shaft very close to the lower looper ensures perfect thread take-up even with elasticized threads

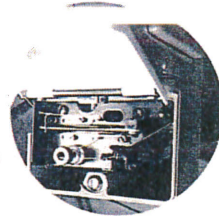

The special and ergonomic structure of the machine, allows the operator to seat properly and to control the fabric easily having a perfect view of the sewing area
A height-adjustable table located under the sewing area makes it easy to pick the semi-finished garments up, for sewing
On another height-adjustable table placed on the right side of the machine the worker can put the finished garment

Feed-off-the-arm heads for closing k The high working speed ensures maximum productiv and best ergonom

The trimming knife unit consists of a mobile knife located above another knife fixed firmly to the presser foot; it trims both of the pieces of fabric to be assembled thus providing a flat seam and aiding fabric feed

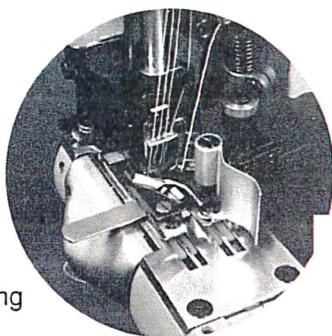

The special shape of the small-diameter cylindrical cross-section base allows even small sized tubular garments to be closed

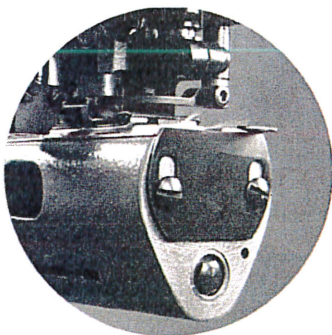

A micrometric mechanical presser foot lifting system which allows feed using elastic blocks; this allows light and delicate fabrics to be sewn and pre-existing seams to be crossed without damage

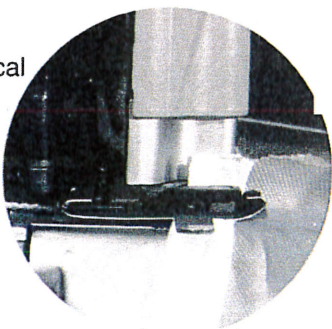

The looper thread tensioning cam located on the left extension of the main shaft very close to the lower looper ensures perfect thread take-up even with elasticized threads

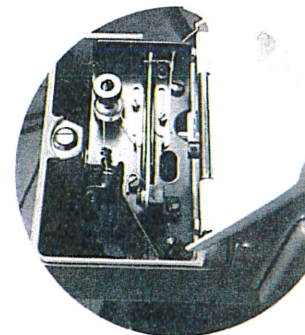

The special and ergonomic structure of the machine, allows the
having a perfect view
A height-adjustable table located under the sewing area makes
On another height-asjustable table placed on the right side

nit garments and hosiery at the sides.
 ty with absolute top quality, complete sewing reliability
 ic working position

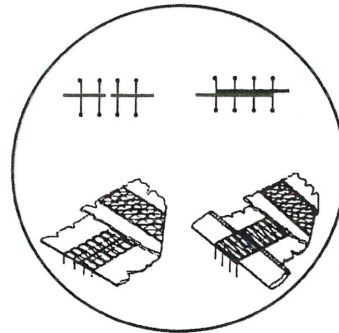
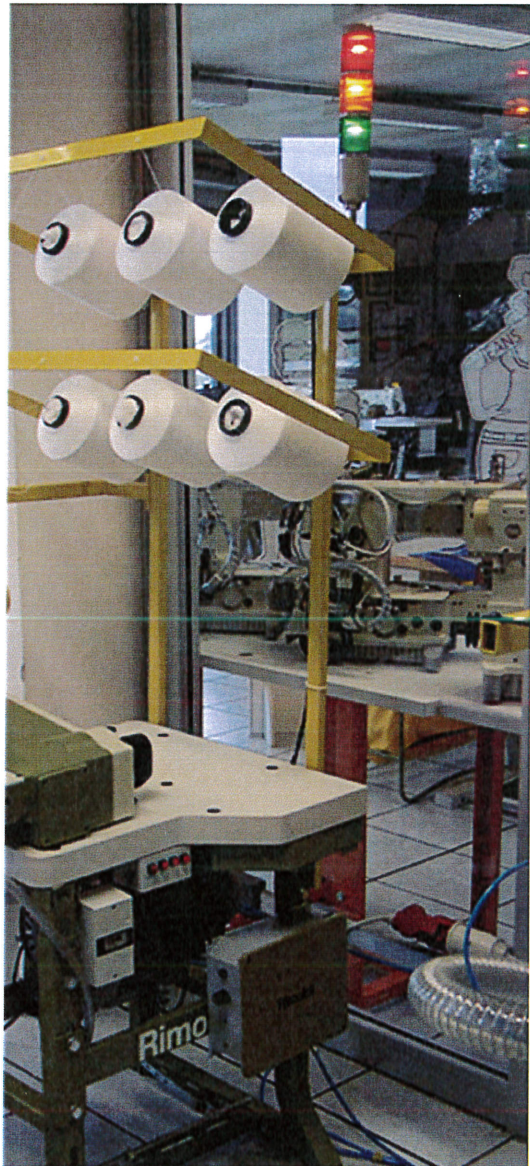

For assembly seams with butted or overlapping edges

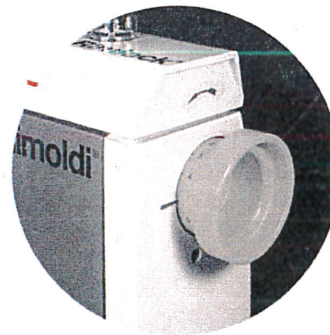

Stitch regulating cam with push-button control and graduated scale on the handwheel in order to read off the stitch length required

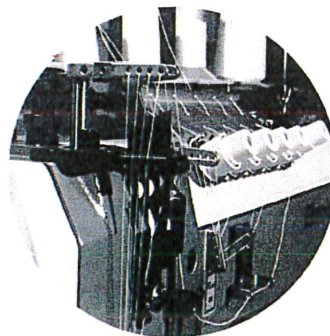

Independent adjustment of needle thread feed which allows the rate of thread fed to each needle to be decided separately according to the elasticity of each thread

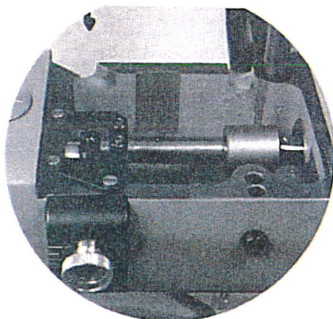

Differential feed which may be easily adjusted using an external lever even when the machine is running

operator to seat properly and to control the fabric easily of the sewing area
 it easy to pick the semi-finished garments up, for sewing of the machine the worker can put the finished garment

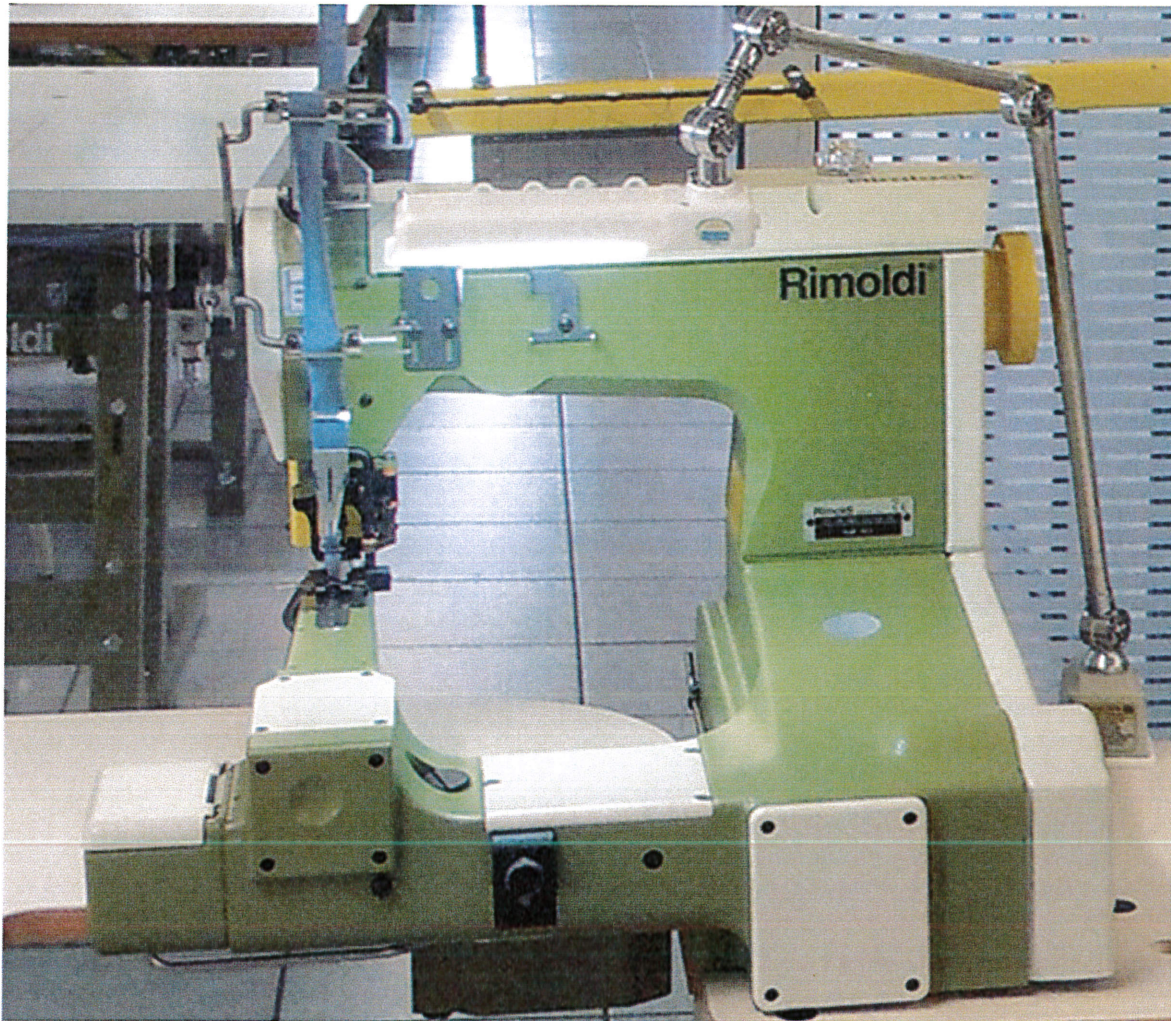

Machine head suitable for seaming the front opening of men's briefs with simultaneous attaching of a reinforcing strip fed from the top.
 Equipped with a folder that turns the strips edges downwards. Width of the cut strips 20 mm finished size 11 mm
 Complete with top tape rack tension to meter the tape properly and with fixed trimming knives located in front of the needles, to trim the edges of the front opening and of the brief in order to obtain a flat seam.

UNDERWEAR

181-38 4 NEEDLES. Sewing machine to attach a reinforcement tape, coming from above, on the front of men's briefs-----

MACHINE								SKETCH OF SEAM	SPECIAL CHARACTERISTICS
---------	--	--	--	--	--	--	--	----------------	-------------------------

181-38-4MR-02	Rim1014	5	8÷15	6	0,6÷1,5	1,5	4.200		Equipped with special presser foot to insert the reinforcement tape behind the trimming knives and folder n. 303375-3-10 (for tape max width 20mm) to obtain a finished fold of 11 mm----- On request an upper tape rack to tension the tape, can be ordered for selvaged tape. (Part number 350290-2-00)-----
---------------	---------	---	------	---	---------	-----	-------	--	---

PERFORMING: the best of the range

- * Feed-of-the-arm with and ergonomic shape to allow the operator to sit with excellent vision of the sewing area-----
- * Foot lift up to 6 mm: to work with heavy fabrics-----
- * The foot is equipped with spring plates to stay in contact with the needle plate, avoiding the fabric slipping during sewing operation. Suitable for light fabric-----
- * Stitch length is adjusted by push button. A graduated scale located on the hand-wheel allows the selection of the stitch length-----
- * Differential feed: easily adjustable to control feeding of fabrics. It can be actuated even when machine is running by a knee press-----
- * Trimming knives: incorporated in the sole of the foot, allows an accurate cutting of the fabric-----

OPERATING: simply & clear

- * Easy control of the fabric-----
- * Ergonomic working position----
- * Reduced operator fatigue-----
- * Clear view of the sewing area----

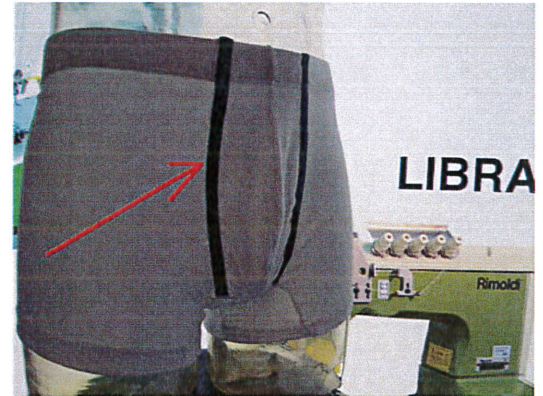

DEVICES

Tape rack, folder and foot

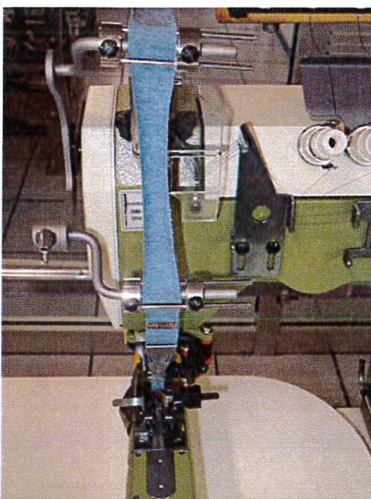

164-15 Knee press pneumatic retractable tape and chain cutter

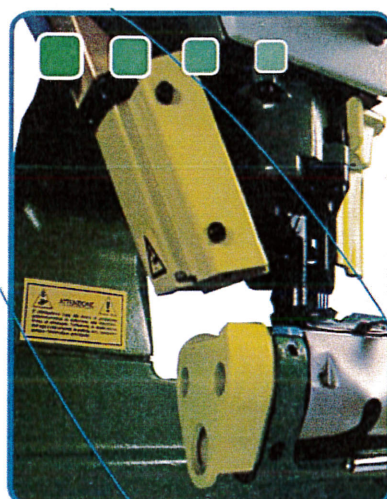

157-30 back treadle pneumatic foot lifter
157-80 Electro pneumatic foot lifter

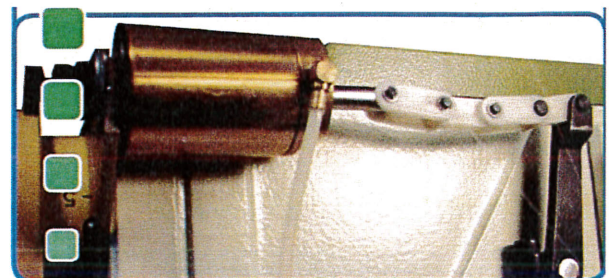

Suggested motors

A3050 1Hp-3 phases-V380 clutch motor
A2875E 1 Hp-750 W-V220-6000rpm electronic motor

Suggested stands

B5180 adjustable stand complete with tables



Machine head suitable for pantyhoses, to execute assembly operations, with or without gusset insertion, to get extremely elastic, resistant and flat seams, with previously trimmed edges. With differential feed and trimming knives located in front of the needles.

The machine will be always set up using customer's fabrics and threads, for garment dyed, which will have to be made of the same raw material.

183-00-4MR-10

MACHINE							a richiesta griffa gommata		SEAM
---------	--	--	--	--	--	--	----------------------------------	--	------

183-00-4MR-10	Rim 1014	6	20-30	6	0,6÷1,6	1,5		4.200	607

PERFORMING: the best of the range

- * Feed-of-the-arm with and ergonomic shape to allow the operator to sit with excellent vision of the sewing area-----
- * Foot lift up to 6 mm: to work with heavy fabrics-----
- * The foot is equipped with spring plates to stay in contact with the needle plate, avoiding the fabric slipping during sewing operation. Suitable for light fabric-----
- * Stitch length is adjusted by push button. A graduated scale located on the hand-wheel allows the selection of the stitch length-----
- * Differential feed: easily adjustable to control feeding of fabrics. It can be actuated even when machine is running by a knee press-----
- * Trimming knives: incorporated in the sole of the foot, allows an accurate cutting of the fabric-----

OPERATING: simply&clear

- * Easy control of the fabric-----
- * Ergonomic working position----
- * Reduced operator fatigue-----
- * Clear view of the sewing area----



DEVICES

299-80 heating chain cutter

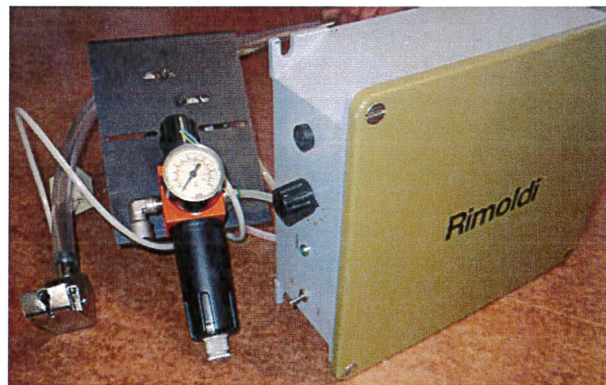

157-30 back treadle pneumatic foot lifter
157-80 Electro pneumatic foot lifter

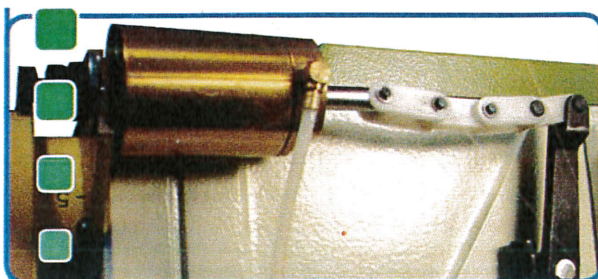

Suggested motors

A3050 1Hp-3 phases-V380 clutch motor
A2875E 1 Hp-750 W-V220-6000rpm electronic motor

Suggested stands

B5180 adjustable stand complete with tables











183-00-4MR-01
183-00-4MR-02

SEAMLESS LINE



Machine head for seamless garments, able to do assembly operations with flat, elastic and resistant seams. Equipped with differential feed and trimming knives located in front of the needles.

The machine will be always set up using customer's fabrics and threads.

MACHINE								SEAM
183-00-4MR-01 Per maglieria leggera e media	Rim1014 	6	3,2	0,6+1,6	6	1,5	4200	
183-00-4MR-02 Per maglieria leggera e media	Rim1014 	6	3,2	0,6+1,6	6		4200	

PERFORMING: the best of the range

- * Feed-of-the-arm with and ergonomic shape to allow the operator to sit with excellent vision of the sewing area-----
- * Foot lift up to 6 mm: to work with heavy fabrics-----
- * The foot is equipped with spring plates to stay in contact with the needle plate, avoiding the fabric slipping during sewing operation. Suitable for light fabric-----
- * Stitch length is adjusted by push button. A graduated scale located on the hand-wheel allows the selection of the stitch length-----
- * Differential feed: easily adjustable to control feeding of fabrics. It can be actuated even when machine is running by a knee press-----
- * Trimming knives: incorporated in the sole of the foot, allows an accurate cutting of the fabric-----

OPERATING: simply & clear

- * Easy control of the fabric-----
- * Ergonomic working position----
- * Reduced operator fatigue-----
- * Clear view of the sewing area----

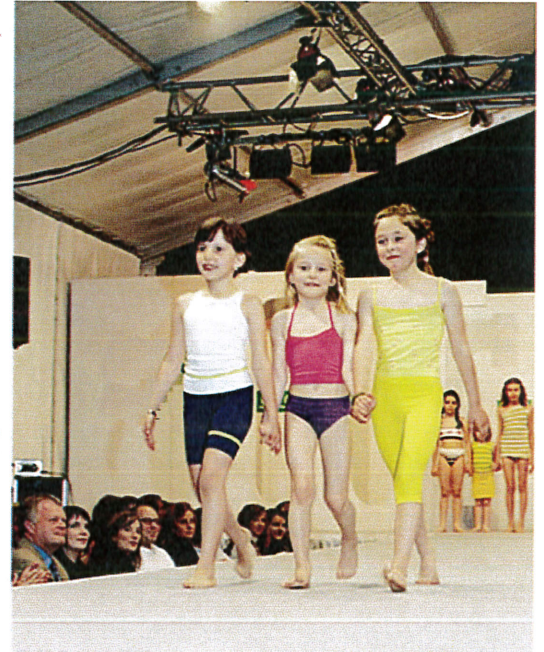

DEVICES

157-30 back treadle pneumatic foot lifter

157-80 Electro pneumatic foot lifter

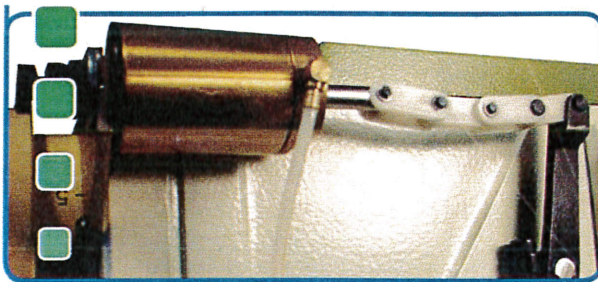

164-15 Knee press pneumatic retractable tape and chain cutter



154-30 pneumatic waste-suction device
154-81 electropneumatic waste-suction device

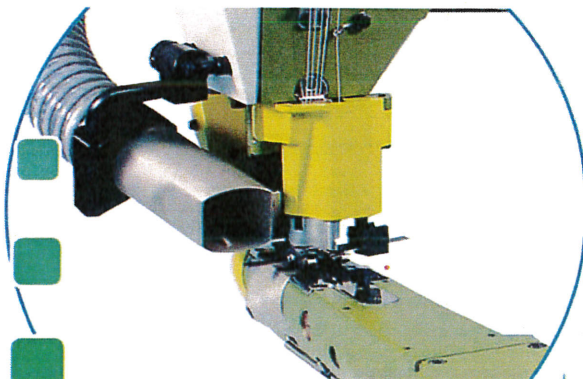

Suggested motors

A3050 1Hp-3 phases-V380 clutch motor
A2875E 1 Hp-750 W-V220-6000rpm electronic motor

Suggested stands

B5180 adjustable stand complete with tables

183-00-4MR-3C

183-00-4MR-4C

SPORTS-AND CYCLING WEAR

Special microfiber thread, appositely prepared for Rimoldi machines for soft and natural seams.



MACHINE							SKETCH OF SEAM	SPECIAL CHARACTERISTICS
183-00-4MR-3C	Rim 1014	6	3,2	0,6+1,6		4200		It is recommended for assembling cyclism garments. Equipped with special foot and guide



MACHINE							SKETCH OF SEAM	SPECIAL CHARACTERISTICS
183-00-4MR-4C	Rim 1014	6	3,2	0,6+1,6		4200		It is recommended for assembling cyclism garments. Equipped with special foot and guide

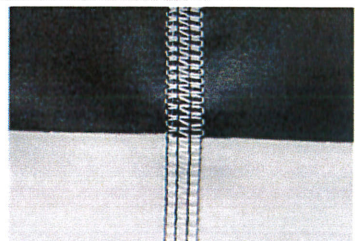
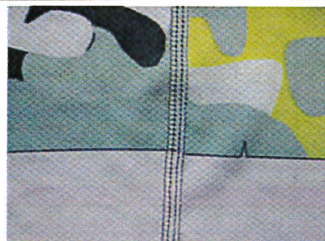
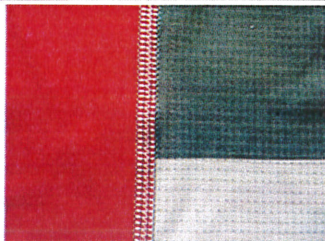

PERFORMING: the best of the range

- * Feed-of-the-arm with and ergonomic shape to allow the operator to sit with excellent vision of the sewing area-----
- * Foot lift up to 6 mm: to work with heavy fabrics-----
- * The foot is equipped with spring plates to stay in contact with the needle plate, avoiding the fabric slipping during sewing operation. Suitable for light fabric-----
- * Stitch length is adjusted by push button. A graduated scale located on the hand-wheel allows the selection of the stitch length-----
- * Differential feed: easily adjustable to control feeding of fabrics. It can be actuated even when machine is running by a knee press-----
- * Trimming knives: incorporated in the sole of the foot, allows an accurate cutting of the fabric-----

OPERATING: simply&clear

- * Easy control of the fabric-----
- * Ergonomic working position----
- * Reduced operator fatigue-----
- * Clear view of the sewing area----

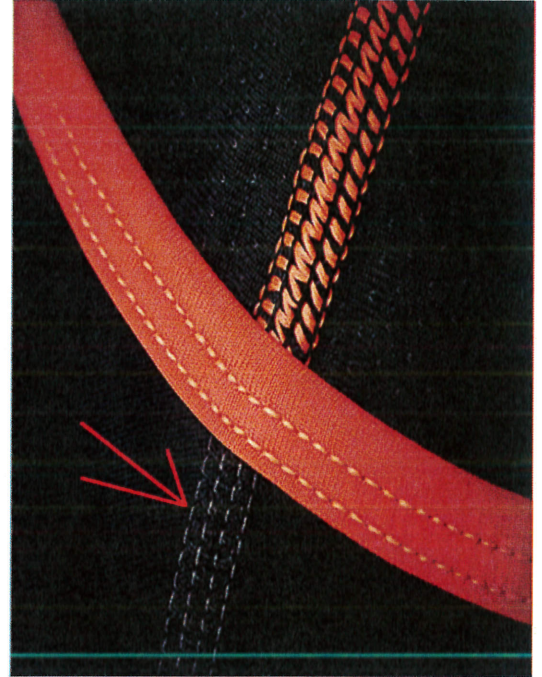

DEVICES

- 157-30 back treadle pneumatic foot lifter
- 157-80 Electro pneumatic foot lifter

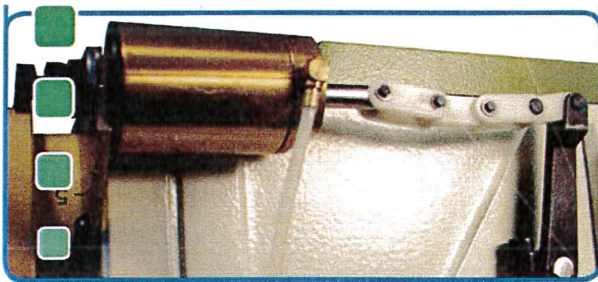

- 164-15 Knee press pneumatic retractable tape and chain cutter

- 154-30 pneumatic waste-suction device
- 154-81 electropneumatic waste-suction device

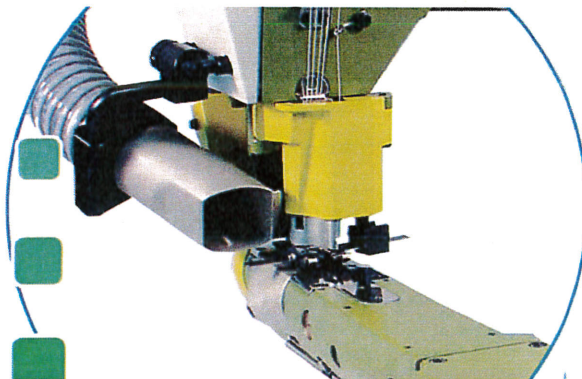

Suggested motors

- A3050 1Hp-3 phases-V380 clutch motor
- A2875E 1 Hp-750 W-V220-6000rpm electronic motor

Suggested stands

- B5180 adjustable stand complete with tables

183-00-4MR-04

UNDERWEAR
T-SHIRT
TIGHTS
CASUAL
SPORTSWEAR

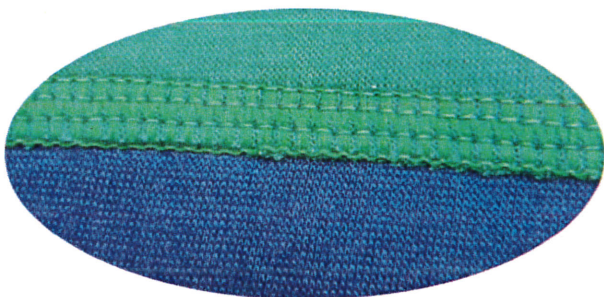
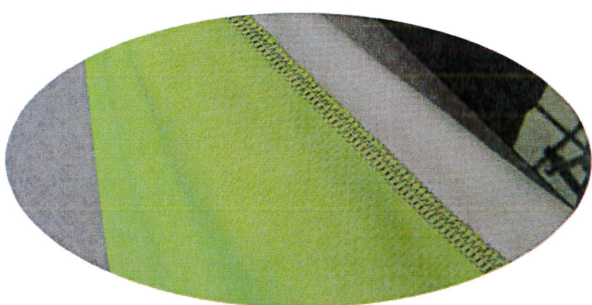
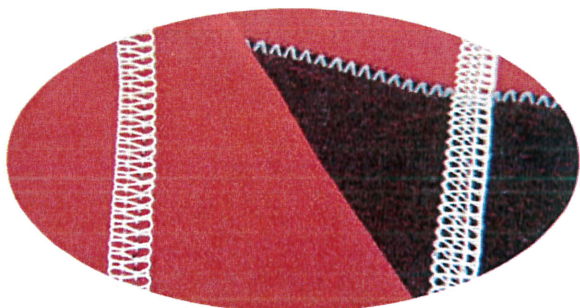

Machine head for gusset application on underwear, for woman's briefs side-closing operation, for shoulders, sides closing and sleeve application on t-shirts and similar items.
Suitable for tights, sweatshirts, casual and sportswear.

The machine will be always set up using customer's fabrics and threads.

MACHINE								SEAM
183-00-4MR-04	B 1014 	6	3,2	6	0,6+1,6	1,5 	4200	

PERFORMING: the best of the range

- * Feed-of-the-arm with an ergonomic shape to allow the operator to sit with excellent vision of the sewing area-----
- * Foot lift up to 6 mm: to work with heavy fabrics-----
- * The foot is equipped with spring plates to stay in contact with the needle plate, avoiding the fabric slipping during sewing operation. Suitable for light fabric-----
- * Stitch length is adjusted by push button. A graduated scale located on the hand-wheel allows the selection of the stitch length-----
- * Differential feed: easily adjustable to control feeding of fabrics. It can be actuated even when machine is running by a knee press-----
- * Trimming knives: incorporated in the sole of the foot, allows an accurate cutting of the fabric-----

OPERATING: simply & clear

- * Easy control of the fabric-----
- * Ergonomic working position----
- * Reduced operator fatigue-----
- * Clear view of the sewing area----

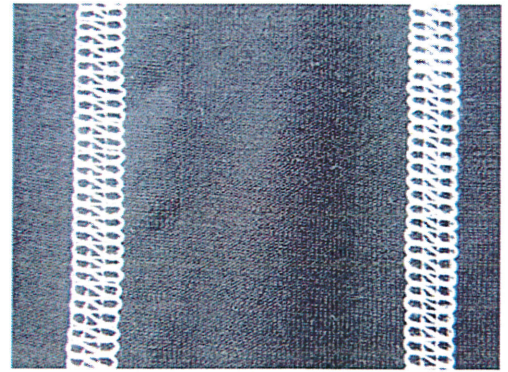

DEVICES

157-30 back treadle pneumatic foot lifter
157-80 Electro pneumatic foot lifter

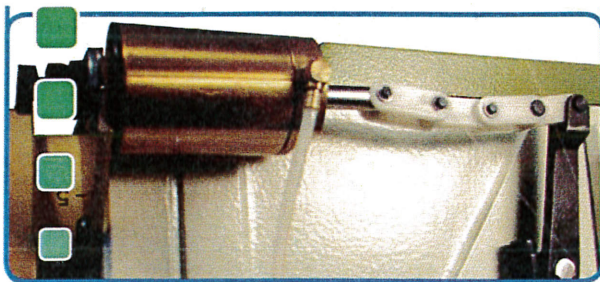

154-30 pneumatic waste-suction device
154-81 electropneumatic waste-suction device

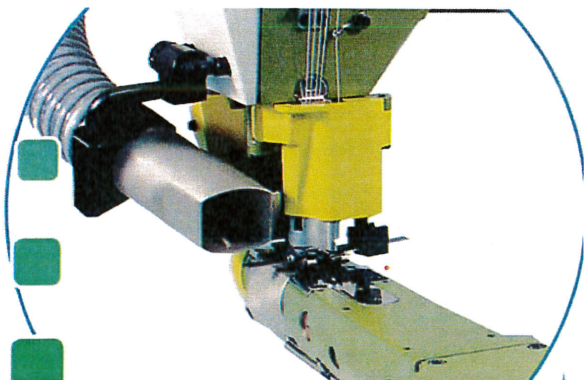

164-15 Knee press
pneumatic retractable
tape and chain cutter

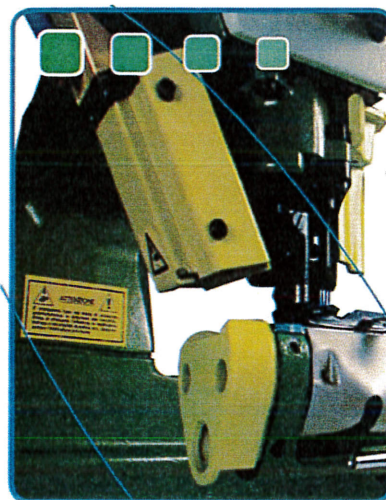

Suggested motors

A3050 1Hp-3 phases-V380 clutch motor
A2875E 1 Hp-750 W-V220-6000rpm electronic motor

Suggested stands

B5180 adjustable stand complete with tables

183-01-4MR-04

MEDICAL ITEMS



Machine head for medical line, especially prepared to insert a stiff or elastic reinforcing tape. Equipped with differential feed and trimming knives located in front of the needles.

The machine will be always set up using customer's fabrics and threads.

MACHINE								SEAM
183-01-4MR-04	B 1014 	6	3,2	6	0,6+1,6	1,5 	4200	

PERFORMING: the best of the range

- * Feed-of-the-arm with an ergonomic shape to allow the operator to sit with excellent vision of the sewing area-----
- * Foot lift up to 6 mm: to work with heavy fabrics-----
- * The foot is equipped with spring plates to stay in contact with the needle plate, avoiding the fabric slipping during sewing operation. Suitable for light fabric-----
- * Stitch length is adjusted by push button. A graduated scale located on the hand-wheel allows the selection of the stitch length-----
- * Differential feed: easily adjustable to control feeding of fabrics. It can be actuated even when machine is running by a knee press-----
- * Trimming knives: incorporated in the sole of the foot, allows an accurate cutting of the fabric-----

OPERATING: simply & clear

- * Easy control of the fabric-----
- * Ergonomic working position----
- * Reduced operator fatigue-----
- * Clear view of the sewing area----



DEVICES

- 157-30 back treadle pneumatic foot lifter
- 157-80 Electro pneumatic foot lifter

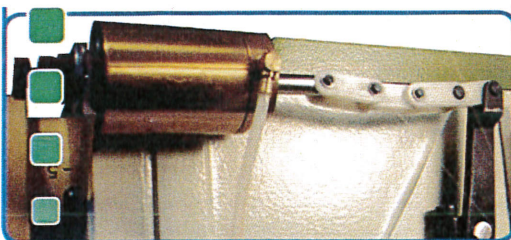

- 164-15 Knee press pneumatic retractable tape and chain cutter

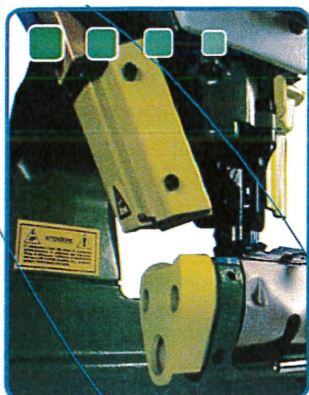

OPTIONAL:

- 154-30 pneumatic waste-suction device
- 154-81 electropneumatic waste-suction device

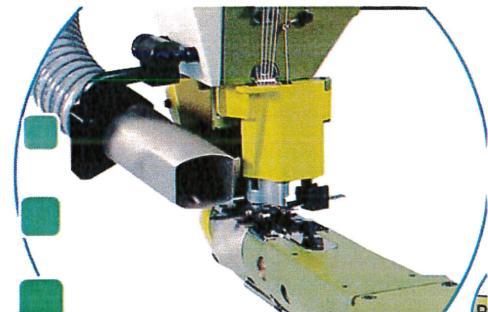

Suggested motors

- A3050 1Hp-3 phases-V380 clutch motor
- A2875E 1 Hp-750 W-V220-6000rpm electronic motor

Suggested stands

- B5180 adjustable stand complete with tables

Rimoldi®



made in Italy

F84

FEED OFF THE ARM HEADS

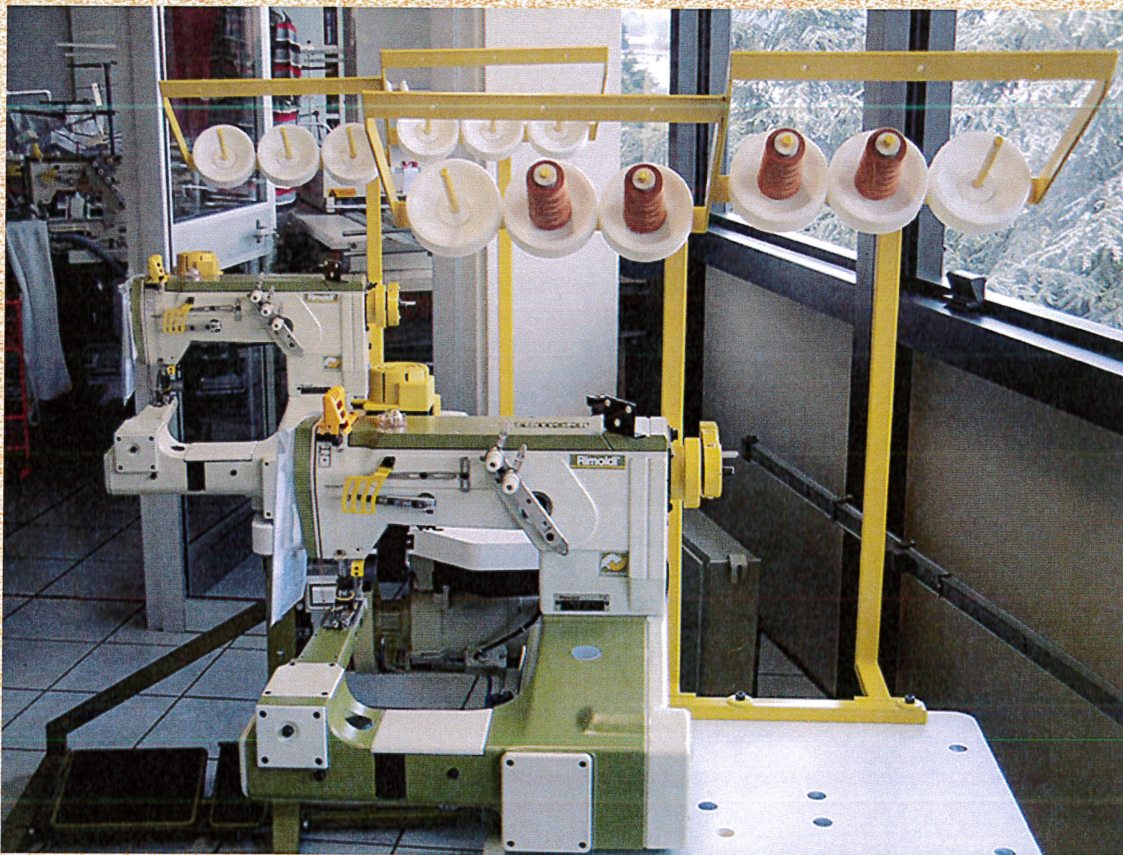









for assembling seams on
a wide range of fabrics

84T-00

Heads with top feed for double lapped seams

Fitted with top feed dog operating in the presser foot in front of the needles, adjustable even when machine is running, for the correct plies pairing with no layers slipping, ensuring a flat and pucker-free seam, an easy insertion of the fabrics under the foot and a constant stitch pitch even at start sewing.

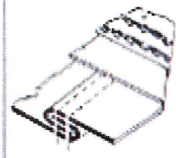
Particular kinematics allow independent adjustment of foot pressure and top feed dog pressure, so that the foot is always in contact with the fabric even when passing over crossway seams or through different thicknesses, thus avoiding stitch skip. An easy mechanical adjustment allows the upper feed dog lift to be adapted to different fabric weights and types.

MACHINE						RPM 	SEWING	NOTES
84T-00-2LA-B4	Uy 128 Gas serv 7	4	5	1+6		4500		For double lapped seams of blue-jeans, sportswear, jackets and workwear made of heavy and very heavy fabric
84T-00-2CA-01	 RIM 64							

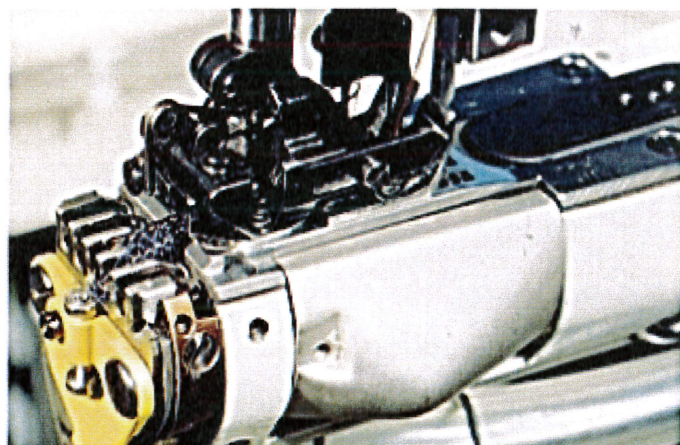
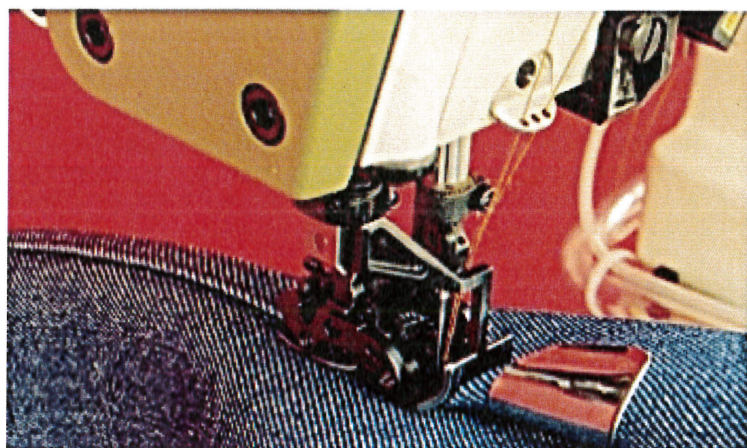

FOLDERS FOR DOUBLE LAPPED SEAMS

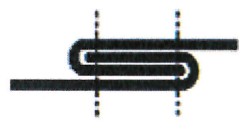
FOLDER SYMBOL	FABRIC WEIGHT	FOR HEADS	SKETCH OF SEWING	NOTES
P351750400 P351751400 P350750400	light medium heavy	F84-00-2CA-11		The double lapped folders are available on request at extra cost to suit the machine and fabric weight type. The outlet is adjustable to suit the thickness of the fabric









F84-00



Heads for double lapped assembly seams

The double lapped folders are supplied on request at extra cost

a) with tractor-feeding-foot

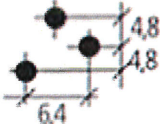

Fitted with tractor feeding-foot with articulated double shoe tact co-operates with the feed dog during fabric feeding. Thus ensuring pucker-free and smooth seams even on slippery fabrics

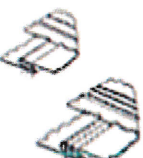
MACHINE						RPM 	SEWING	NOTES
F84-00-2CA-11	Rim64 	4	2,3	•		6000		Particularly suitable for closing sides and sleeves of shirts, pyjamas, dressing gowns and similar garments made of light and medium weight woven fabrics For warp and weft light fabric

F84-00-3CA-11	Rim 64 	6	3,5	11+20	6000		401 	Equipped with a tractor feeding foot operating with the feed dog assuring perfect lap seams and covering stitch seams. It can be used for 2 or 3 needles seams
---------------	--	---	-----	-------	------	--	---	--

b) with puller

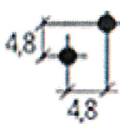
Fitted with rear pullers (the upper driving and the lower driven) which cooperate at the feeding of fabric as so as ensure a regular feeding of the semi-finished garments; they have their own movement which is intermittent and their speed is variable

F84-00-2MK-11	Rim 64 	4	3,5	11+20	4700	401 	Equipped with a tractor feeding foot operating with the feed dog assuring perfect lap seams and the overcrossing of existing seam Particularly suitable for warp and weft medium fabric. With rear pulle closto needles
---------------	---	---	-----	-------	------	--	--

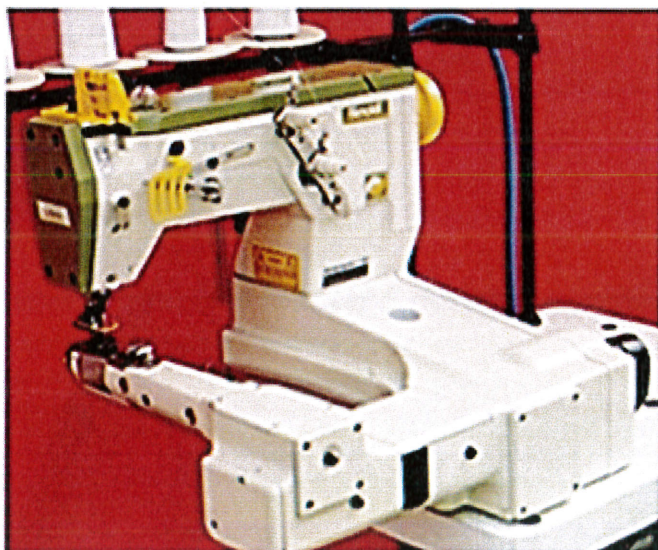



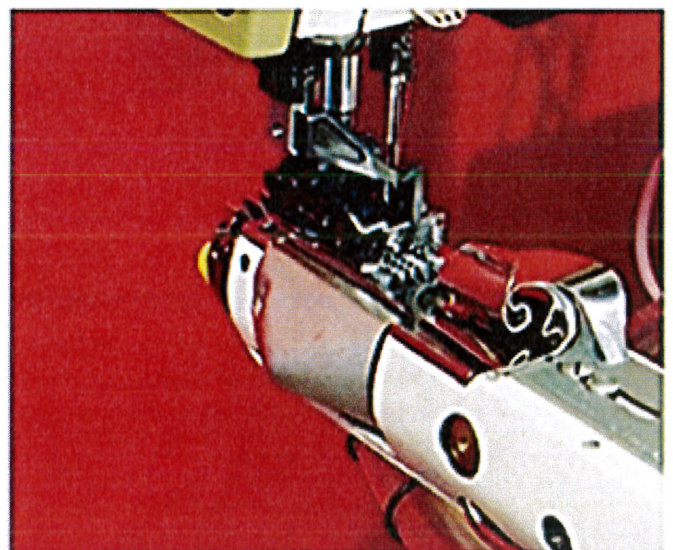



F84-00-2CA-11 for shirts

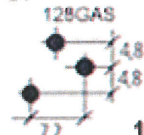

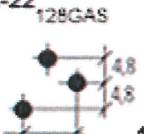
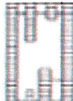
Tractor feeding foot and doublelapped folder of F84-00-2CA-11 HEAD

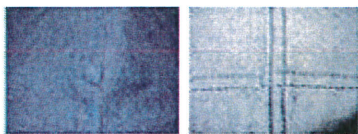
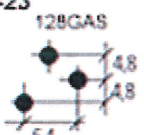
Jeans and casualwear F84-00 3 needles

F84-00-3LK-21 6 2,5  14 OZ		5+18	4700	 Suitable for double lap seaming on blue-jeans and sportwear. Puller behind the needles to assure the same stitch length even during change of speed
F84-00-3LK-22 6  14 OZ		5+18	4700 	 
F84-00-3LK-23 6  10-12 OZ		5+18	4700	 Work station for double lap seaming operations on blue-jeans and sportswear. With rear puller closed to the needles for heavy-medium fabric.

FOLDERS FOR DOUBLE LAPPED SEAMS

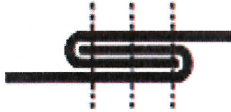
FOLDER SYMBOL	FABRIC WEIGHT	FOR HEADS	SKETCH OF SEWING	NOTES
P350750400 P350752400 P350753400	H heavy MH medium HX heavy	F84-00-3LK-21/23 F84-00-3LK-22 F84-00-3LK-21/23		The double lapped folders are available on request at extra cost, to suit the machine and the fabric weight type. The outlet is adjustable to suit the thickness of the fabric.

AVAILABLE DEVICES

164-15: KNEE PRESS "SCISSOR TYPE" CHAIN CUTTER-----

259-30: TREADLE CONTROL NEEDLE-COOLING DEVICE-----

259-80: EV NEEDLE-COOLING DEVICE CONTROLLED BY ELECTRONIC MOTOR-----

296-30: BACK-TREADLE VERTICAL-TYPE CHAIN-CUTTER-----

296-80: EV PNEUMATIC VACUUMING CHAIN CUTTER CONTROLLED BY ELECTRONIC MOTOR-----

170-10: KNEE PRESS DEVICE FOR DIFFERENTIAL FEED ADJUSTMENT EVEN WHEN MACHINE IS RUNNING-----

257-30: BACK TREADLE PNEUMATIC PRESSER FOOT LIFTER-----

257-80: EV PNEUMATIC PRESSER FOOT LIFTER CONTROLLED BY ELECTRONIC MOTOR-----

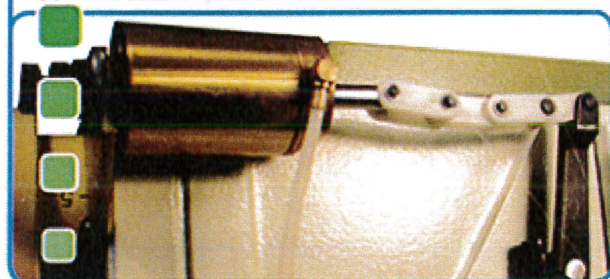

STAND: B5181 ADJUSTABLE STAND

MOTOR: A3050- A2875E

Rimoldi has always paid particular attention to meeting market needs and expectations. It is also extremely aware of the problem of final user safety and optimizing the conditions of use of its machines. For this reason, the machines are certified CE

Rimoldi®

F84-00-3LK-22/25730
Jeans 14 once

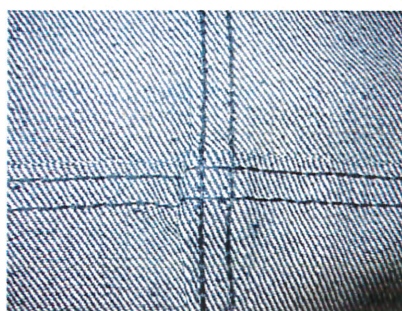

Special kit:

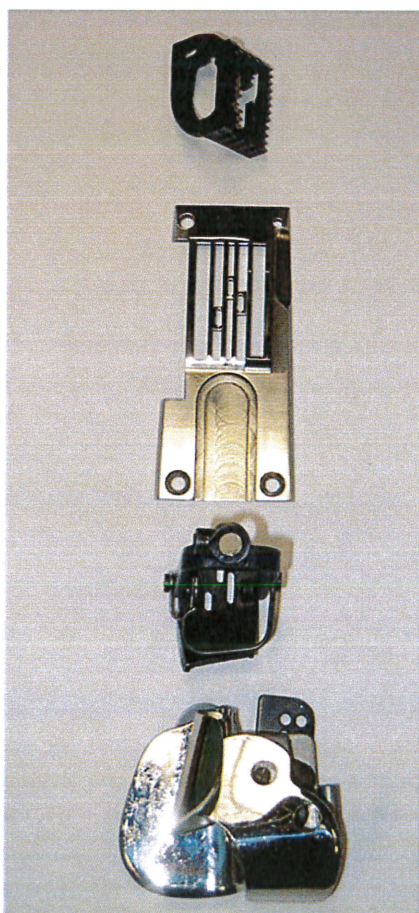

P351295400

P351424000

P353135300

P350753400

 **made in Italy**

Rimoldi®

 made in Italy

VEGA

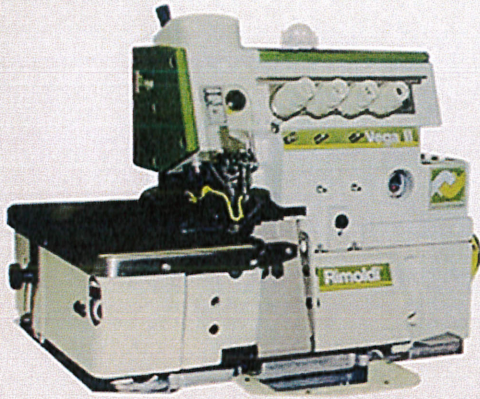

FENIX

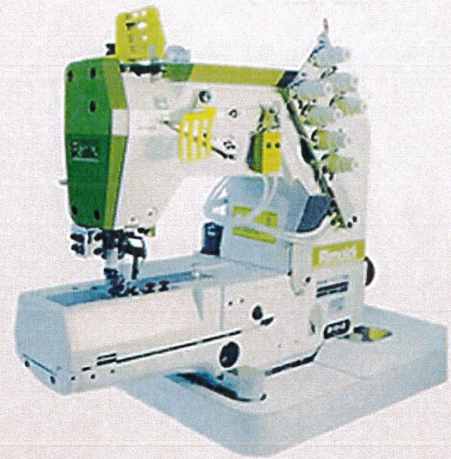

SIRIO

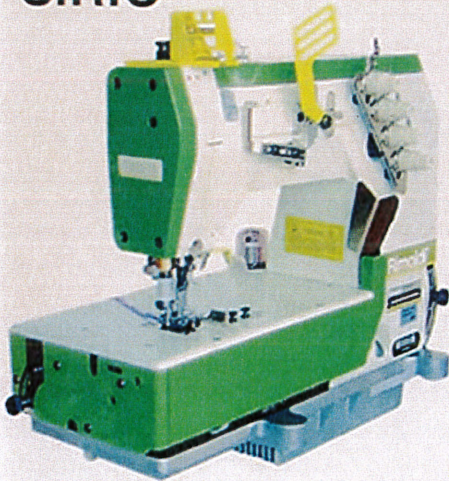

FLEXSYSTEM®

ALTAIR

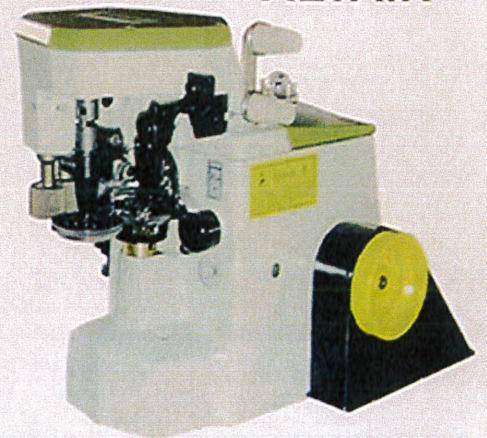

LIBRA



Rimoldi & CF srl Corso C. Colombo, 46 21013 Gallarate ITALY -
Tel. +39 0331 75071 Fax +39 0331 750781
info@rimoldiecf.com www.rimoldiecf.com